

P50

The professional rack passthrough dishwasher

**POWERFUL. EFFICIENT.
SIMPLE TO USE.**



LET'S WORK!

It washes whatever may come along. Powerfully and hygienically clean. Also during peak times. And: It impresses with how simple it is to use and its efficient operation. The P50 rack passthrough dishwasher by Winterhalter offers a professional warewashing solution at an cost-effective price: developed according to the highest German quality standards – manufactured in Asia. And therefore specially tailored for Asian market requirements.



FEATURES (OPTIONAL)

- integrated softener
- Built-in EnergyLight waste water heat exchanger
- dosing device and suction poles

FEATURES (STANDARD)

WASHING PROGRAMMES: The P50 makes washing as easy as possible: with only two programmes. A standard programme for normal soiling, and a HighTemp programme that meets Thermolable specifications.

WASH FIELD: The heart of the P50: Two elliptical wash fields at the top and bottom deliver optimal wash results. The special shape of the wash fields and the geometry of the jets guarantee washing power over the entire surfaces with minimal rinse water volume.

HYGIENE CONCEPT: Behind the P50 is a carefully thought-out concept for perfect hygiene and convenient cleaning. The interior is smooth and has no joints. The deep-drawn tank and a hygiene rear panel prevents limescale and dirt deposits. In combination with the self-cleaning programme, cleaning work is reduced to a minimum.

FILTRATION: The cleaner the wash water, the fewer changes of water are required. And the better the wash result: Coarse dirt is caught by a strainer. A fine filter with removable filter cassette takes care of smaller dirt particles. And the pump inlet filter protects the pump from mechanical damage.

EXTREMELY EASY TO USE: Inexperienced employees? High staff turnover? No problem: The P50 is intuitive to operate. The colour-coded display has self-explanatory and language-neutral pictograms. It displays the machine's current operating mode at a glance: heating, ready for operation or washing. The washing programme starts up automatically after closing the hood. Numerous control functions ease the burden on the staff even more: for example the simple process to call up the current tank and boiler temperatures.

LOW CAPACITY WASH TANK: The tank volume of the P50 has been reduced to the bare minimum. The advantage: Operating costs are reduced and the machine is ready to use very quickly.

THERMOSTOP: Rinsing makes a decisive contribution to the quality of the wash result. The correct temperature is important here. The P50 controls this automatically: The Thermostop starts the rinsing cycle only when the temperature in the boiler has reached its set value.

EASY SERVICING: Quick maintenance and troubleshooting: The integrated error management system and simple access to the components make the U50 particularly easy to service. For example, if the filter is blocked, the machine will immediately indicate this with a pictogram in the display.

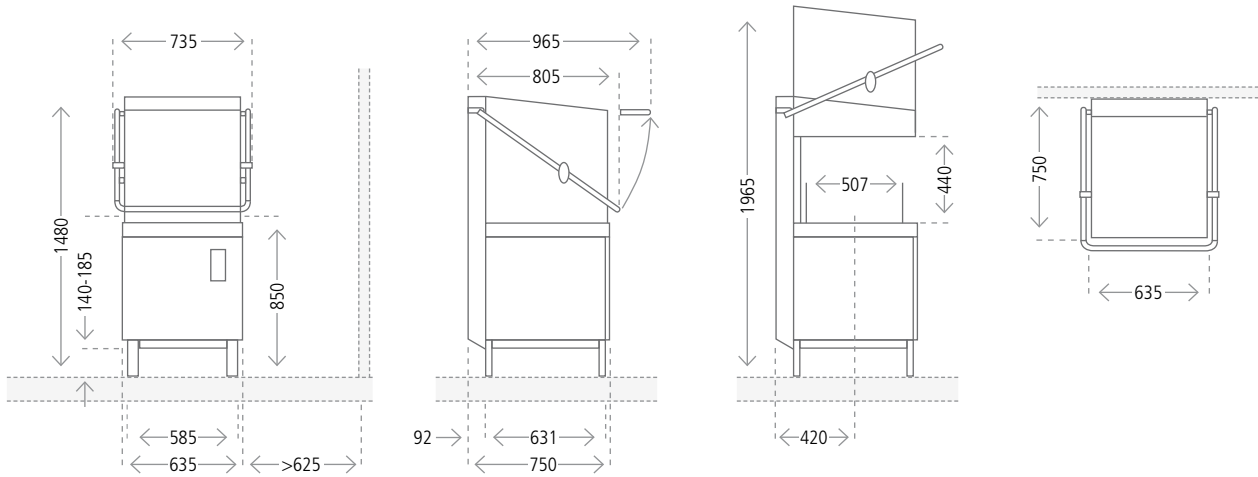

TECHNICAL DATA

Number of programmes		2
Theoretical capacity*1 standard / HighTemp	racks / h	60 / 20
Rack dimensions	mm	500 x 500
Water consumption		
Tank capacity	l	28
Rinse water consumption*2 per wash cycle Standard / HighTemp	l	2.4 / 3.8
Temperatures		
Tank temperature standard / HighTemp	° C	62 / 66
Rinse temperature	° C	85
Max. water inlet temperature	° C	60
Other information		
Circulating pump (P1)	kW	0.6
Noise emission	dB(A)	max. 63
Packaging dimensions	racks / h	770 x 880 x 1605
Splash guard		IP X3
Weight net / gross	kg	98 / 123

ELECTRICAL SPECIFICATIONS

Supply	Fuse	Tank	Boiler	Total connected load
380 V – 415 V, 3N~, 50 Hz / 60 Hz	16 A	2.5 kW	9.0 kW	9.3 kW
	20 A	2.5 kW	9.0 kW	11.8 kW
220 V – 240 V, 3~, 60 Hz	25 A	2.5 kW	9.0 kW	9.3 kW
	32 A	2.5 kW	9.0 kW	11.8 kW

*1 Depending on the local conditions (water inlet temperature / electrical supply) the indicated data can decrease.

*2 Non-binding information. The actual need for rinse water can vary depending on the on-site conditions.

Authorized Dealer

Brilliance Refrigeration Systems

#235 C1, Bommasandra Industrial Area,
Bangalore 560099

Tel: +91-99000 13450

enquiry@brilliance.co.in
brilliance.co.in

